

Table of Contents

| | |
|---|----|
| IsoMet® 1000 Precision Saw | 5 |
| Warranty | 5 |
| Unpacking | 5 |
| Safety Information | 7 |
| Machine Use and Care | 7 |
| Installation | 8 |
| Electrical Installation | 8 |
| Activating the IsoMet® 1000 Precision Saw | 9 |
| Blade Installation | 9 |
| Gang Sawing | 10 |
| Flanges | 10 |
| Blade Dressing | 10 |
| Lubrication | 11 |
| Operation | 12 |
| IsoMet® 1000 Front Control Panel | 13 |
| Sample Arm | 14 |
| Loading the Saw | 15 |
| End of Cut Adjustment | 16 |
| Cutting a Sample | 16 |
| Maintenance | 18 |
| Trouble Shooting Chart | 18 |
| IsoMet® 1000 Accessories | 19 |
| Chucks | 19 |
| Flanges | 19 |
| Other | 19 |
| Wafering Blades | 20 |

IsoMet® 1000 Precision Saw

The IsoMet® 1000 Precision Saw offers increased speed, load, and blade size that enables a wide variety of specimen samples to be cut quickly and with low deformation.

The IsoMet® 1000 cutting compartment is fully enclosed and can be removed and replaced with the accessory Table Saw Attachment for sectioning larger samples. The coolant tray can be easily removed from the front of the machine for fast cleaning and for easy retrieval of cut samples.

With a 7-inch diamond blade capacity and a wide selection of accessories, the IsoMet® 1000 Precision Saw offers increased versatility and power for sectioning today's advance materials.

Warranty

This unit is guaranteed against defective material and workmanship for a period of two (2) years / 2000 hours from the date of receipt by the customer. The warranty is void if inspection shows evidence of abuse, misuse, unsafe use, or unauthorized repair. This warranty covers all Buehler costs associated with the replacement of defective materials (e.g., parts, labor, and travel).

If for any reason this unit must be returned to Buehler Ltd. for warranty service, please apply for prior authorization with shipping instructions. Please include the following information:

- Customer Purchase Order Number
- Buehler Invoice Number and Date
- Serial Number
- Reason for return

Unpacking

The IsoMet® 1000 Precision Saw has been carefully packaged to protect it during transit from the factory to your location. Carefully unpack and check the contents. If any components are missing or damaged, save the packing list and materials and advise the carrier and Buehler, Ltd. of the discrepancy.

Carefully unpack and check that the following items have been received:

- 11-1184 Bar and Tube Stock Chuck
- 11-1185 Irregular Specimen Chuck
- 11-1186 Wafering Chuck
- 11-1187 Small Single Saddle Chuck
- Pint IsoCut® Fluid
- Series 15LC 6-inch Diamond Wafering Blade
- 2 3-inch Flanges
- Hex Wrench $\frac{1}{8}$ inch
- Hex Wrench $\frac{3}{32}$ inch
- Hex Wrench $\frac{5}{32}$ inch
- Hex Wrench $\frac{5}{64}$ inch
- Open End Hex $\frac{1}{2}$ - $\frac{5}{8}$ inch



WARNING! **Equipment Damage.** The IsoMet® 1000 Precision Saw weighs 75 lbs (34 kg) and two persons are required to safely lift the unit from the shipping carton.

The IsoMet[®] 1000 Precision Saw is bolted to a wood base for protection during shipping. Open areas are provided at the corners of the base for ease of lifting. Lift IsoMet[®] 1000 Precision Saw out of the carton and position it on a table so it overhangs on the edge. Remove the bolts securing the IsoMet[®] 1000 Precision Saw to the wood base.

Note: Do not remove the four bolts securing the motor to the IsoMet[®] 1000 housing (see Figure 1).

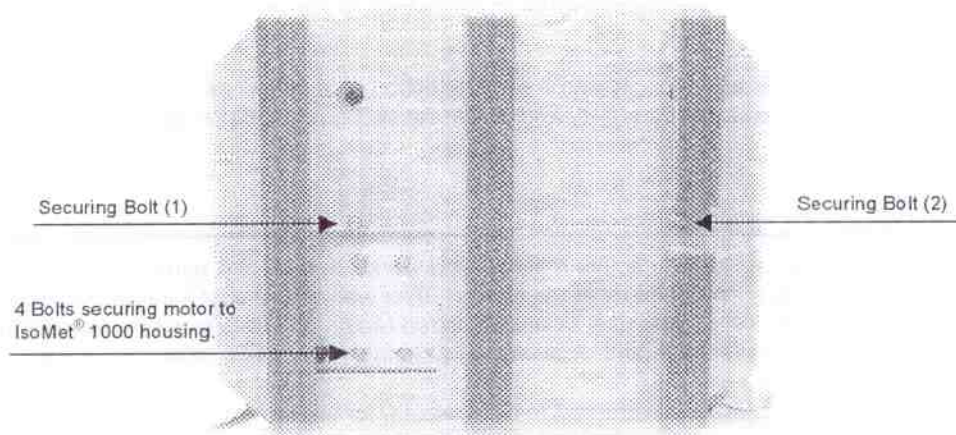

Figure 1 IsoMet[®] 1000 Wood Base

Safety Information

The IsoMet[®] 1000 Precision Saw is designed to section metallurgical and petrographic materials with recommended cutting wheels.

For safe installation and operation of this equipment, carefully read and understand the contents of this manual. Improper operation, handling, or maintenance can result in equipment damage and personal injury.

The IsoMet[®] 1000 Precision Saw is designed for use in dry, indoor laboratory and workshop environments away from strong electromagnetic fields and with normal temperature ranges (41° F to 104° F / 5° C to 40° C) and non-condensing humidity ranges (30-90%).

Machine Use and Care

Dress properly. Do not wear loose clothing or jewelry and contain long hair. They can be caught in moving parts and can result in severe personal injury. Protective equipment should be worn to handle samples, which may be sharp or hot.

Do not operate machine in explosive atmospheres, such as in the presence of flammable liquids, gases, or dust. Sparks may ignite the dust or fumes.

Always use safety glasses. Flying debris and liquids can cause severe eye injury.

Maintain the IsoMet[®] 1000 Precision Saw with care. Properly maintained machines are less likely to bind and are easier to control. Any alteration or modification is a misuse and may result in a dangerous situation.

Maintain machine guards and interlocks. Do not attempt to enter the cutting bay when the IsoMet[®] 1000 Precision Saw is in use.

Only qualified repair personnel must perform machine service. Service or maintenance performed by unqualified personnel could result in a risk of injury.

Replace damaged or defective parts immediately and use only identical replacement parts. Use of unauthorized parts or failure to follow maintenance instructions may create a risk of electrical shock or injury.

Check for misalignment or binding of moving parts, breakage of parts, and any other condition that may affect the machine operation. If damaged, have the machine serviced before using. Poorly maintained machines cause many accidents.

Do not abuse the power cord. Never use the cord to cart the machine or pull the plug from an outlet. Keep the cord away from heat, oil, sharp edges, or moving parts. Replace damage cords immediately. Damage cords increase the risk of electrical shock.

Use of extension cords is not recommended for Buehler machines and equipment.

Machine coolant can present a biological hazard if not maintained correctly. Change the coolant regularly in accordance with local regulations and safety practices.

- Coolant must be suitable for grinding cut-off use and protect against electrolytic action between sample material and machine.

Installation



CAUTION! Equipment Damage. Follow all locally approved procedures and safety practices when lifting and installing this machine. Improper lifting can result in machine damage.

Select a location for your IsoMet[®] 1000 Precision Saw that provides an adequate working space and a power source.

The IsoMet[®] 1000 Precision Saw is 15 ½ inches (394 mm) wide, 21 inches (533 mm) deep, and 12 inches (305 mm) high. Placement of the IsoMet[®] 1000 Precision Saw should be on a sturdy, level bench. Buehler TECH-MET[®] tables are highly recommended.

Allow 6 inches (150 mm) of space at the back of the IsoMet[®] 1000 Precision Saw for raising the hood. Make sure to leave sufficient space on both sides for sectioning long bars.

Electrical Installation



WARNING! Electrical Shock Hazard. Do not change the power plug in any way. Buehler machines are equipped with a polarized plug (one blade is wider than the other) and a ground pin. Polarized plugs reduce the risk of electrical shock. This plug will fit in a polarized outlet only one way.

Check that Specification Plate values for voltage, current, and power consumption are compatible with the intended electrical supply before installation.

The IsoMet[®] 1000 Precision Saw can be plugged into an outlet rated for the voltage and frequency listed on the Specification Plate.



WARNING! Electrical Shock Hazard. A qualified electrical technician should perform electrical maintenance.

- *Disconnect the power supply before making any electrical adjustments.*
- *Capacitors inside the machine may retain a charge even if the machine is disconnected from the power supply.*
- Installation of the IsoMet[®] 1000 Precision Saw must comply with local electrical standards or codes of practice.

| IsoMet [®] 1000 Precision Saw | Voltage / Frequency |
|--|-----------------------------|
| 11-2180 | 85 – 264 Volts / 50 – 60 Hz |

Table 1 IsoMet[®] 1000 Electrical Data

Activating the IsoMet[®] 1000 Precision Saw

To activate power to the IsoMet[®] 1000 Precision Saw flip the power switch on the back of the machine to the UP position.

The IsoMet[®] 1000 power switch is also a two-pole circuit breaker that will provide protection for the machine in the event of an overload.

If at any time the Front Control Panel buttons or the motor does not operate, reset the IsoMet[®] 1000 by flipping the power switch to the DOWN position then back to the UP position.

Blade Installation

1. Remove the thumbscrew, end cap bushing, and outer flange from the arbor shaft (see **Figure 2**).
2. Install the blade on the arbor shaft against the inner flange.
3. Slide the outer flange, the end cap bushing, and the thumbscrew on to the arbor shaft.
4. Hand tightened the thumbscrew to secure the blade.

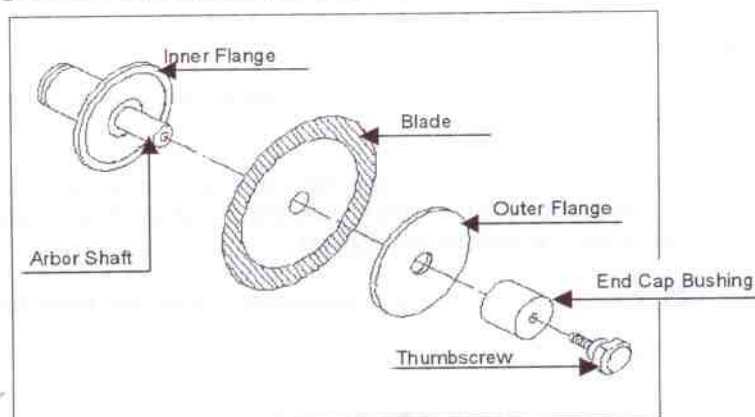

Figure 2 Blade Installation

Gang Sawing

Several blades can be installed to the IsoMet® 1000 for gang sawing.

1. Install the blades with the appropriate spacers.
2. Slide the outer flange, the end cap bushing, and the thumbscrew on to the arbor shaft.
3. Hand tightened the thumbscrew to secure the blades.

Flanges



CAUTION! Equipment Damage. Flanges provide support for wafering blades. Failure to provide adequate flange support can result in curved cuts and damaged blades.

Always select the maximum flange diameter to correspond with the sample size.

Before re-installing a wafering blade, clean the flanges, end cap bushing, and thumbscrew. This will help prevent misalignment of the blade and prevent poor quality cuts.

Blade Dressing

New wafering blades (including the original equipment blade) must be dressed before making any cuts.

Blade dressing removes built up matrix metal and exposes the abrasive grain to provide clean, aggressive cutting. New wafering blades should be dressed several times and older blades should be dressed as required.

Note: When cutting metal, it may be necessary to dress the blade after each cut.

To dress a wafering blade:

1. Position the dressing stick in the dressing chuck.
 - From the front of the machine, pull the lubricant tank straight out until the blade makes contact with the back of the tank. The dressing chuck will now be exposed.
 - Position the dressing stick as needed.
 - Close the lubricant tank.
2. Close the hood.
3. Press the SAW button to activate the saw.
4. Rotate the Dressing Stick Feed Control knob clockwise to feed the dressing stick into the wafering blade (see **Figure 3**).

5. Make as many cross cuts through the dressing stick as needed to dress the blade. Three to five crosscuts usually work well.

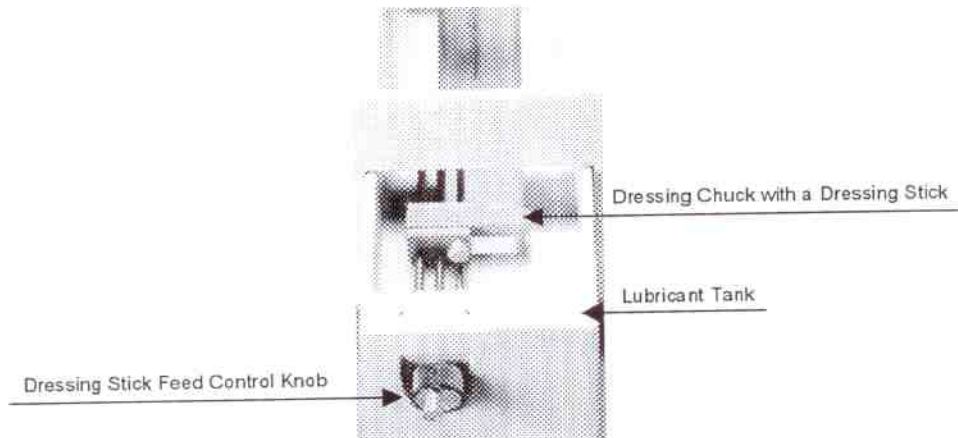

Figure 3 Dressing Chuck inside the Lubricant Tank



WARNING! Personal Injury. Feeding the dressing stick or any specimen sample into the blade by hand can result in severe personal injury and equipment damage.

Lubrication

The IsoMet[®] 1000 Precision Saw uses the drag principle of lubrication. The lubricant is carried to the sample on the edge of the rotating blade.

IsoCut[®] Plus Fluid reduces cutting time and produces superior cuts. IsoCut[®] Plus Fluid is best for most metals and many non-metals. The use of IsoCut[®] Plus Fluid promotes effective lubrication enables diamond particles to cut cleanly and minimizes loading of the blade.

- Fill the IsoMet[®] 1000 lubricant tank with IsoCut[®] Plus Fluid to a level that will immerse the blade approximately ¼-inch.
- Discard the lubricant when becomes contaminated with sludge.
 - a. Remove the sample tray, wafering blade, and flanges from the arbor shaft.
 - b. From the front of the machine, pull the lubricant tank straight out.
 - c. Discard the lubricant in a safe and approved manner.
 - d. Clean the lubricant tank.
 - e. Reinstall the lubricant tank.
 - f. Refill the lubricant tank with fresh, clean lubricant.
 - g. Reinstall the wafering blade, flanges, and sample tray.

Operation

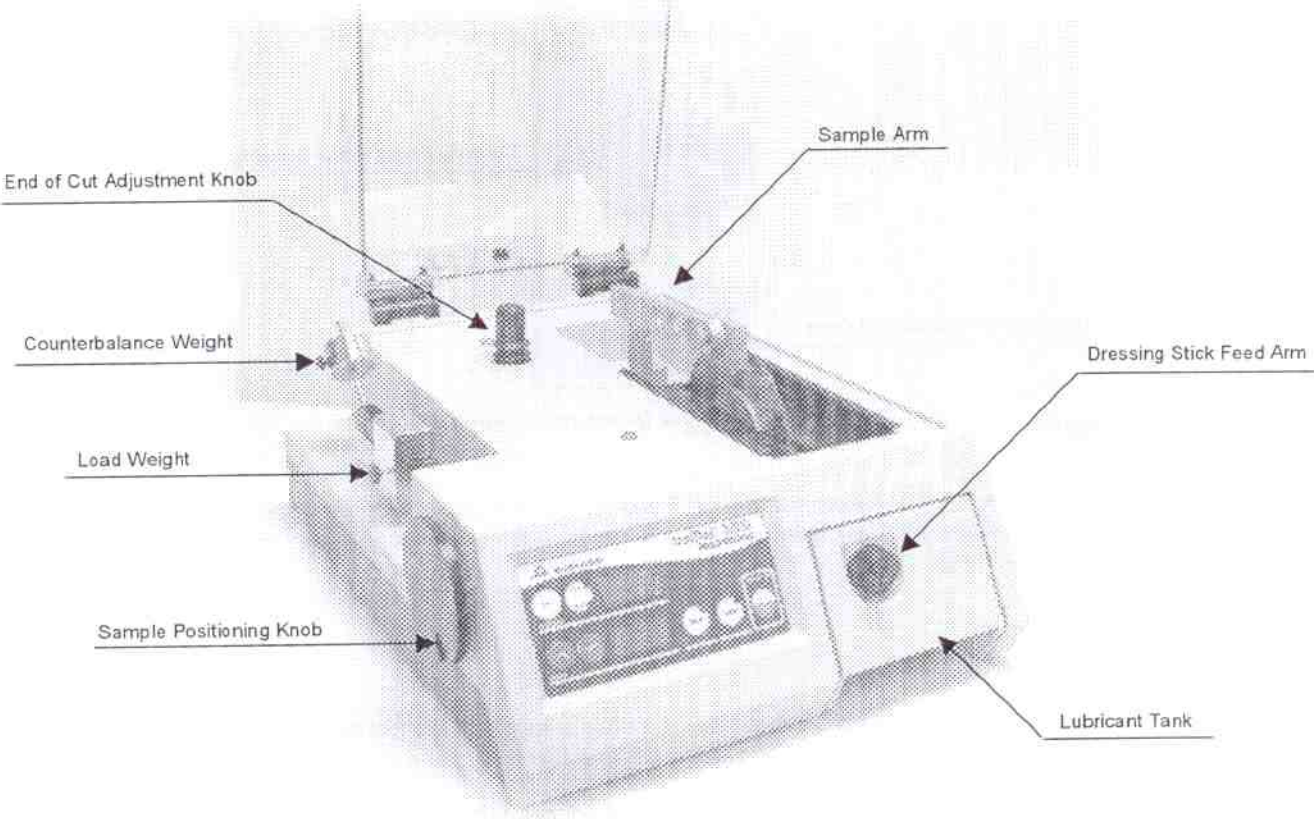

Figure 4 IsoMet® 1000 Precision Saw Components

IsoMet® 1000 Front Control Panel

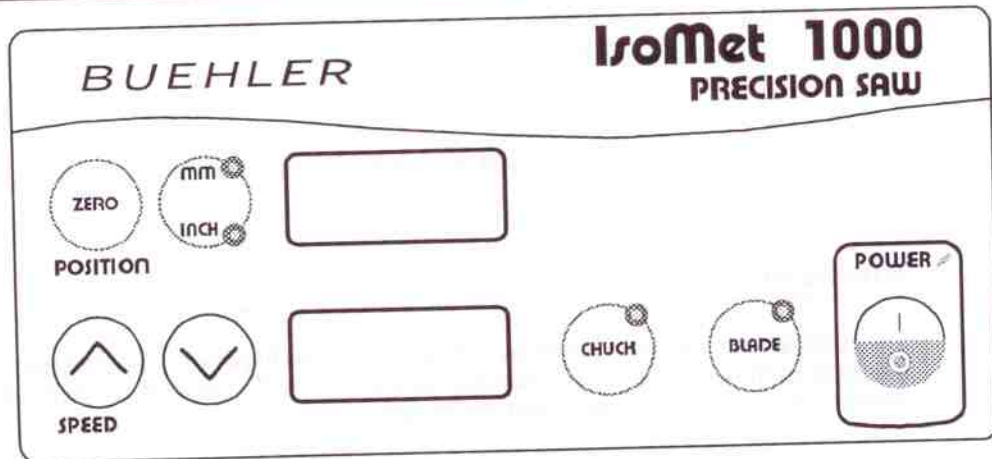







Figure 5 IsoMet® 1000 Front Control Panel

-  **POSITION (ZERO)** Resets the blade position to zero. The POSITION LCD will display 00.0.
-  **UNITS (MM / INCH)** Displays either millimeters or inches as the unit of measurement in the POSITION LCD.
The default unit of measurement is inches. The indicator light will light up for the unit of measure selected.
- POSITION FIELD** Displays the distance of the blade from the set ZERO position.
-  **INCREASE** Increases the blade speed in increments of 25 rpms. Press and hold the INCREASE button for rapid speed selection.
-  **DECREASE** Decreases the blade speed in increments of 25 rpms. Press and hold the DECREASE button for rapid speed selection.
- SPEED FIELD** Displays the blade speed in rpms. The minimum blade speed is 100 rpms. The maximum blade speed is 950 rpms.
Note: The IsoMet® 1000 will retain to the last selected speed.
-  **CHUCK** *Only used with the Rotating Chuck accessory.* Activates and deactivates the Rotating Chuck. The indicator light will light up when the chuck is activated.



BLADE

Activates and deactivates the blade. The indicator light will light up when the blade is running.



POWER

Activates and deactivates power to the IsoMet® 1000.

Sample Arm

The Sample Arm has three positions to select from (see **Figure 6**). The position selected depends on the diameter of the wafering blade (4-inch to 7-inch) and the angle of engagement between the blade and the sample.

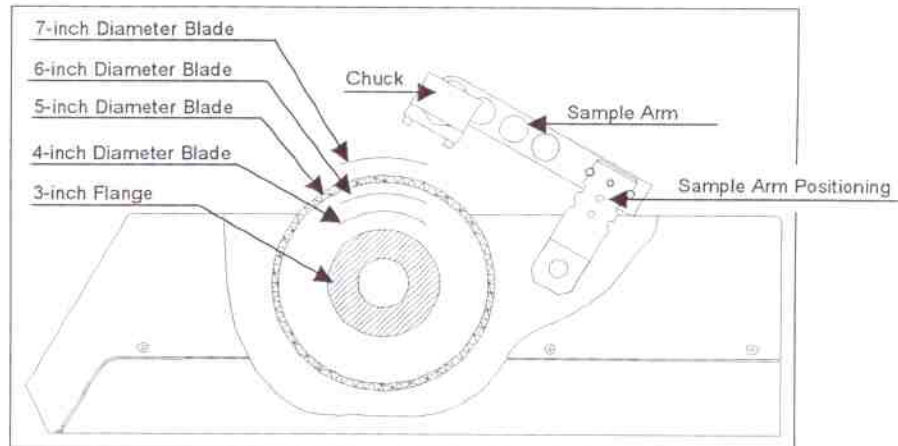

Figure 6 Sample Arm Positioning

Loading the Saw

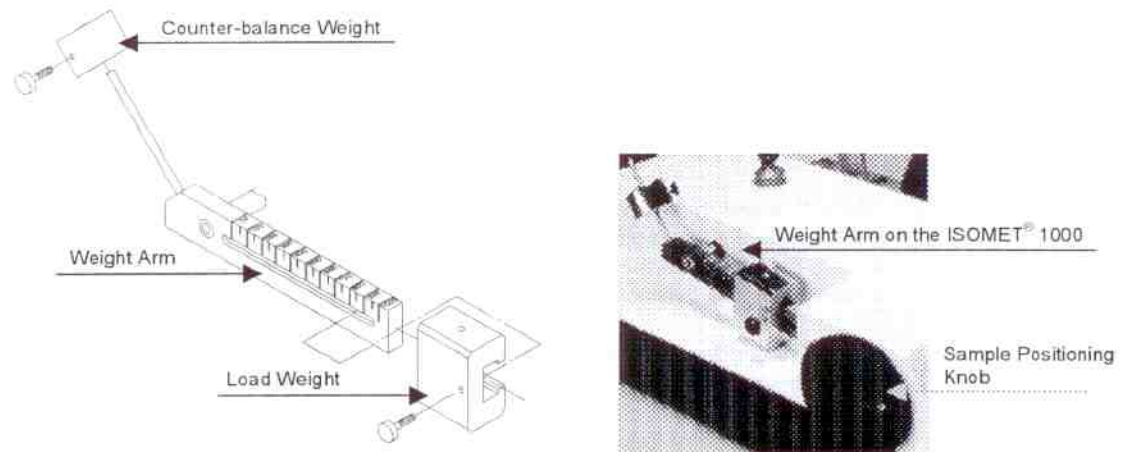

Figure 7 Weight Arm

1. On the left side of the IsoMet[®] 1000 is the Weight Arm. Lift the Weight Arm to the locked position.
2. Loosen the thumbscrew on the Load Weight.
3. Slide the weight to the zero setting.
4. Select the proper chuck for the application and clamp the sample in the chuck.
 - To clamp odd or irregular samples, it may be necessary to sandwich metal strips between the sample and the chuck.
5. Attach the sample loaded chuck to the Sample Arm with the supplied screw (a socket head cap).
6. Once the chuck is secure, rotate the Sample Positioning knob to move the Sample Arm to the far left.
7. Lower the Weight Arm so it lays horizontal.
8. Slide the counter-balance weight up or down until a balance is achieved.
9. Tighten the thumbscrew on the counter-balance weight to secure the weight.
 - If a large chuck or a heavy sample is used, a balance may not be achieved.
 - If the sample is load sensitive, deduct the unbalanced weight from the Load Weight setting.
10. Set the Load Weight to the desired load as marked on the Weight Arm.
 - The Weight Arm is calibrated from zero (0) to 500 grams. 300 grams of additional weight can be added with the optional weight kit.
 - Lighter weights are recommended since heavier loads can cause greater surface damage to the sample.

End of Cut Adjustment

The End of Cut Adjustment knob is located under the hood on the IsoMet® 1000 housing (see **Figure 8**).

The End of Cut Adjustment knob sets the total travel of the Sample Arm and stops the blade when the travel is complete. This End of Cut feature can also be used to cut a sample to a certain depth.

The arm travel can be set to stop the saw either just before a cut is complete or when a cut is complete. By setting the End of Cut feature to deactivate the saw just before a cut is complete reduces the weight on the sample and prevents the possible burring or cleavage of fragile materials near the end of a cut.

An alternative for minimizing burring and to prevent cleavage of fragile materials is to use a double saddle chuck.

Note: The End of Cut feature must be positioned and set to prevent the sample and/or chuck from riding on the blade flanges after the cut is complete.

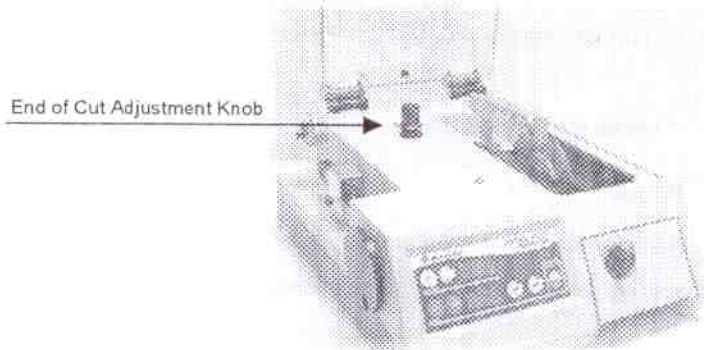

Figure 8 IsoMet® 1000

Cutting a Sample

1. Using the appropriate chuck, load the sample and chuck on to the Sample Arm.
Note: Do not scratch the blade or drop a sample on the wafering blade's edge.
2. Raise the Sample Arm to adjust the position of the sample.
3. Rotate the Sample Positioning knob to move the sample left or right.
 - The Front Control Panel will display the numerical movement of the sample.
4. Lower and hold the Sample Arm with the sample just above the wafering blade.
5. Rotate the Sample Positioning knob until the sample touches the side of the wafering blade.
6. Press the DISPLAY (ZERO) button to reset the POSITION LCD to zero (00.0).

7. Raise the Sample Arm to the locked position.
8. Press the UNITS button to display millimeters or inches.
9. Advance the sample as required.
10. Close the hood.
11. Press the SAW (RUN/STOP) button to activate the blade.
12. Press the INCREASE or DECREASE buttons to set the blade speed.
Note: Faster speeds (and heavier weights) tend to damage the sample surface.
13. The cut cycle will begin.
14. If the End of Cut Adjustment has been set, the blade will automatically stop when the cut is complete.

Maintenance

The IsoMet[®] 1000 Precision Saw will continue to perform at optimum levels with proper care, daily cleaning, and general maintenance.

The protective hood and touch-panel control pad should be cleaned using mild soap and water applied with a soft cloth. **Do not** use ammonia-based cleaners, i.e. Windex[®]. Cloudiness and cracking can occur.

Exterior painted surfaces, including the cutting chamber, should be cleaned with a non-abrasive household cleaner.

Note: When the IsoMet[™] is used in a Hot Cell or Glove Box, the inert atmosphere may cause excessive motor brush wear. Brushes may need to be replaced monthly. This replacement is not covered under the warranty

Trouble Shooting Chart

| Problem | Possible Cause | Correction |
|--|---|---|
| The IsoMet [®] does not power on. | The unit is not plugged in. | Check the power cord connection. |
| | The unit is not powered on. | Check the rear power switch. |
| The blade keeps pinching. | Wrong blade for the material. | Replace with correct blade. |
| | Improper sample fixture (primary cause). | Use correct sample fixture. |
| | Blade may need to be dressed. | Dress blade. |
| The bed has rust on it. | Improper coolant mixture. | Check the coolant for proper mixture. |
| | The hood has been closed too long with moisture build up. | Open hood and keep hood open when not in use. |
| The Rotating Chuck does not work. | Cable is disconnected. | Check the cable connection. |
| | Rotating chuck is not powered on. | Make certain the Rotating Chuck is turned on. |
| Coolant leaks from the IsoMet [®] . | Table or unit is not level. | Make certain the table is level. |
| | Coolant level too high. | Check the volume of cutting fluid. |

IsoMet® 1000 Precision Saw Accessories

IsoMet® 1000 Accessories

| Catalog No. | Description |
|---|--|
| Chucks | |
| 11-1183 Chuck | Double Saddle Type |
| 11-1184 Chuck | For Bar and Tube Stock |
| 11-1185 Chuck | For Irregular Shaped Specimens |
| 11-1186 Chuck | For Wafers Single Crystals and Thin Sections |
| 11-1187 Chuck | For Long Samples, Single Saddle Type |
| 11-1188 Chuck | For Petrographic and Ceramographic Thin Sections |
| 11-1189 Chuck | For 1-inch or 1 ½-inch Diameter Specimens (Requires the use of 11-1192 Recessed Flanges) |
| 11-2482 Fastener Chuck | For Longitudinal Sectioning of Fasteners, Tubes, and Solid Cylinders |
| 11-2489 Specimen Chuck | For 1 ½-inch and 40 mm Mounted Samples |
| 11-2483 Double Saddle Chuck | 1-inch Diameter Capacity |
| 11-2484 Glass Slide Chuck | 27 mm x 46 mm Glass Slide for Thin Sections |
| 11-2488 Glass Slide Chuck | 2-inch x 3-inch Glass Slide for Thin Sections |
| 11-2496 Chuck Padding | Applied to Chucks for Holding Brittle or Friable Specimens |
| Flanges | |
| 11-1191 Flange | 1 ½-inch Diameter, Recessed |
| 11-1192 Flange | 1 ¾-inch Diameter, Recessed (For use with 11-1188 Chuck and 11-1189 Chuck) |
| 11-2282 Flange | 3-inch Diameter |
| 11-2283 Flange | 4-inch Diameter |
| 11-2284 Flange | 5-inch Diameter |
| Other | |
| 11-1190 Dressing Stick | For Dressing Series 15 and 20 Wafering Blades |
| 11-1290 Dressing Stick | For Dressing Series 5 and 10 Wafering Blades |
| 11-2181 Rotating Chuck Accessory | For Holding and Rotating Samples up to 2-inch in Diameter |
| 11-2182 Table Saw Attachment | For Hand-Cutting Long or Irregular Specimens |
| 11-2186 Splash Shield | For use with the 11-2182 Table Saw Attachment |
| 11-2183 Accessory Weight Set | For Increasing Cutting Load to 800 gm |
| 11-2185 IsoMet® 1000 Goniometer | For Sectioning Crystals |
| 11-2293-016 IsoCut® Cutting Fluid | 1 Pint (.48 liter) |

IsoMet[®] 1000 Precision Saw Accessories

Wafering Blades

| Blade Series | Diameter and Thickness | | | | |
|---|------------------------------|-------------------------------|-------------------------------|------------------------------|------------------------------|
| | 3" x 0.006" (75 x 0.2 mm) | 4" x 0.012" (100 x 0.3 mm) | 5" x 0.015" (125 x 0.4 mm) | 6" x 0.020" (150 x 0.5mm) | 7" x 0.025" (180 x 0.6mm) |
| 30 HC | | | 11-4239** | | 11-4241** |
| For use with plastics, polymers, and rubber | | | | | |
| 20 HC | | | 11-4215* | | 11-4237 |
| For aggressive general sectioning of ferrous and non-ferrous materials | | | | | |
| 15 HC | 11-4243 | 11-4244 | 11-4245 | 11-4246 | 11-4247 |
| For routine use, metal matrix composites, PC boards, and thermal spray coatings | | | | | |
| 20 LC | | | 11-4225* | | 11-4227 |
| For use with hard/tough materials, structural ceramics, boron carbide, boron nitride, silicon nitride | | | | | |
| 15 LC | 11-4253 | 11-4254 | 11-4255 | 11-4276 | 11-4277 |
| For use with hard/brittle materials, structural ceramics, electronic substrates, alumina, zirconia, silicon carbide | | | | | |
| 10 LC | 11-4283 | | 11-4285 | | 11-4287 |
| For use with medium to soft ceramics, electronic packages, GaAs, AlN, and glass fiber reinforced composites | | | | | |
| 5 LC | 11-4289 | | 11-4295 | | |
| For use with soft friable ceramics, composites with fine reinforcing media, CaF ₂ , MgF ₂ , and carbon composites | | | | | |
| ISOCUT | 11-4263 | 11-4264 | 11-4265 | 11-4266 | 11-4267 |
| Wafering Blades: For iron and cobalt based alloys, nickel base super alloys, and lead base alloys | | | | | |

****Alternate Blade Thickness of 0.020" (0.5 mm)**

***Alternate Blade Thickness of 0.030" (0.8 mm)**

IsoMet® 1000 Precision Saw Drawings

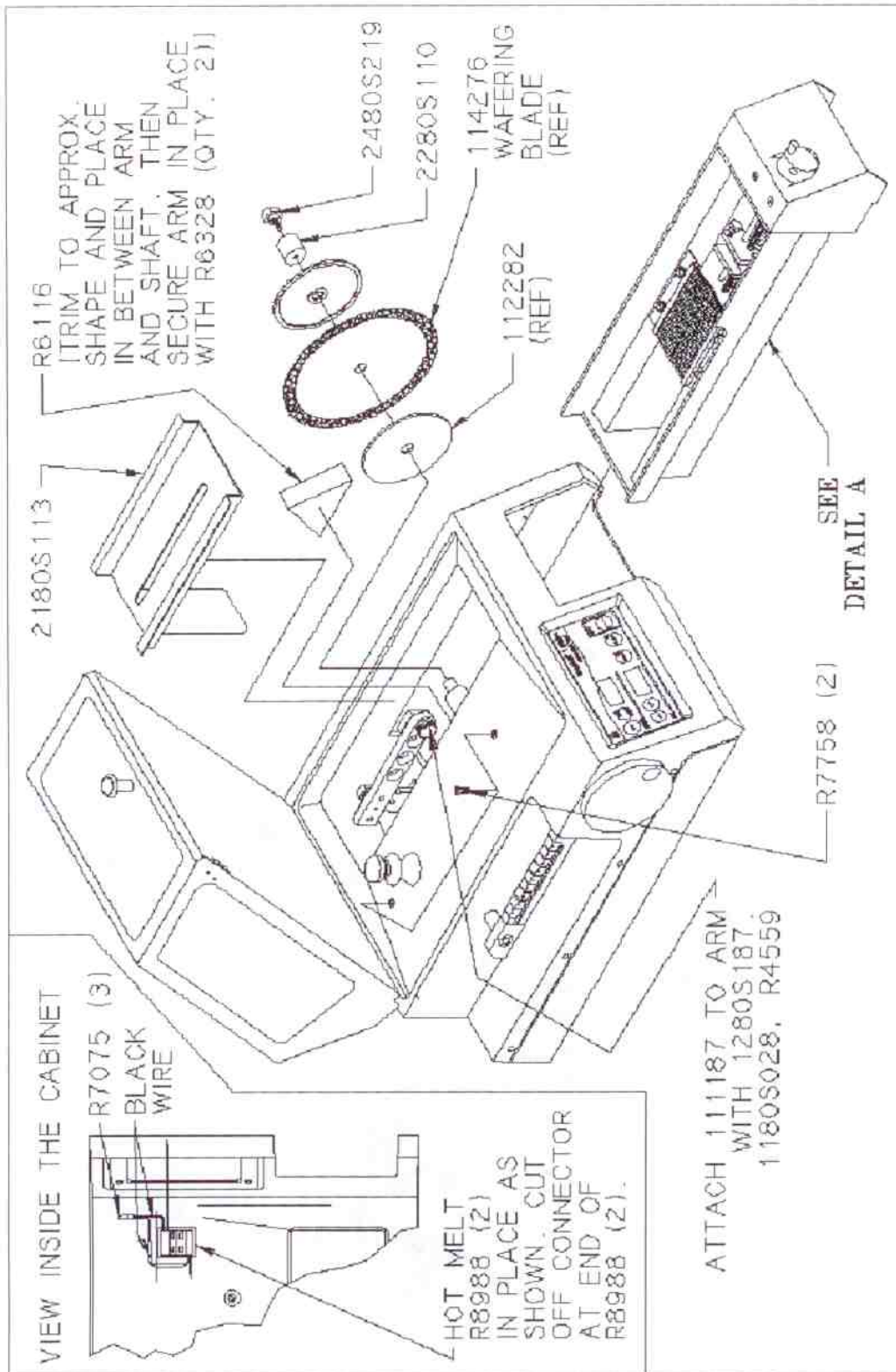

Figure 9 IsoMet® 1000 Assembly Diagram

IsoMet® 1000 Precision Saw Drawings

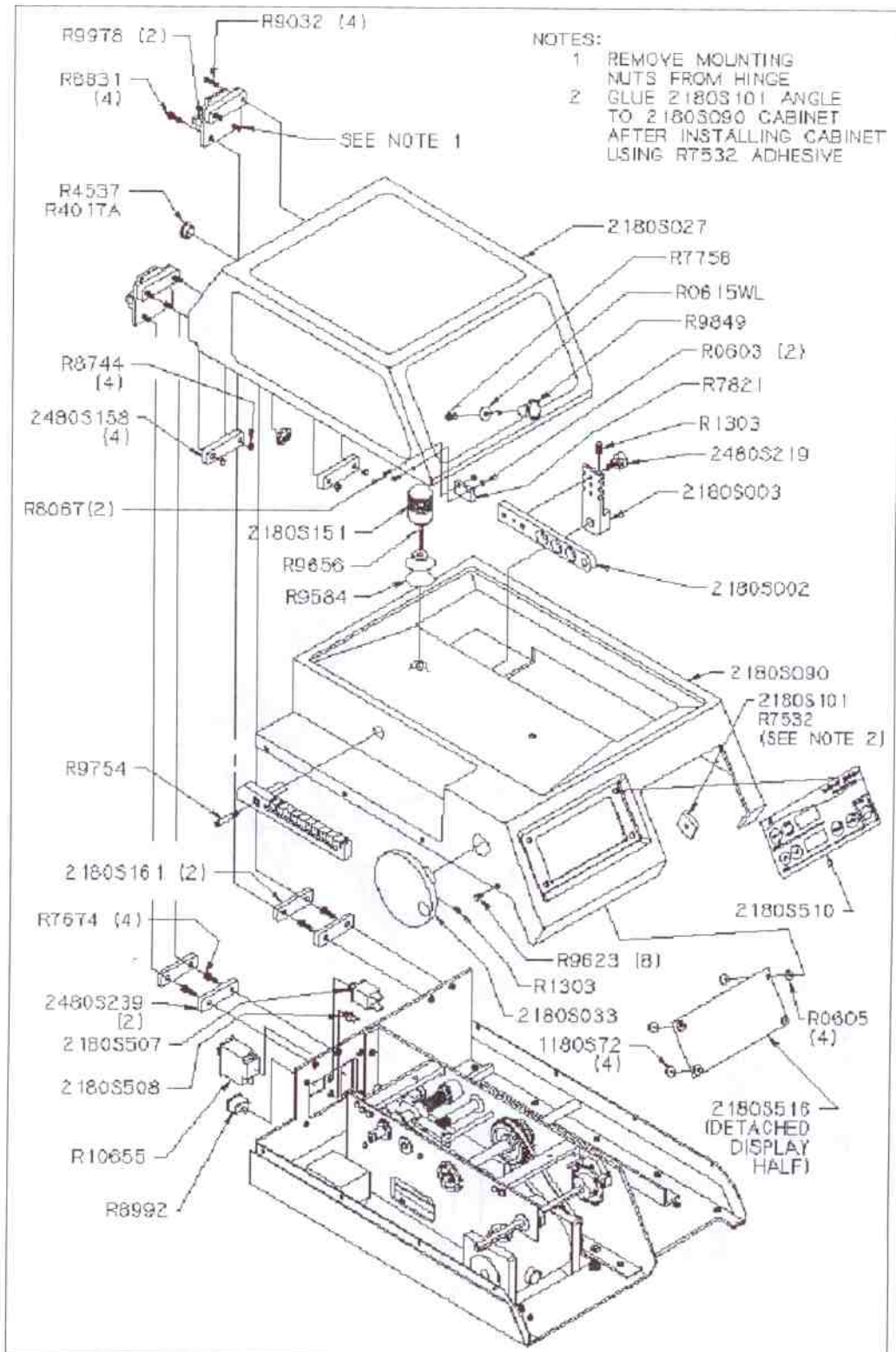

Figure 10 IsoMet® 1000 Assembly Diagram

IsoMet® 1000 Precision Saw Drawings

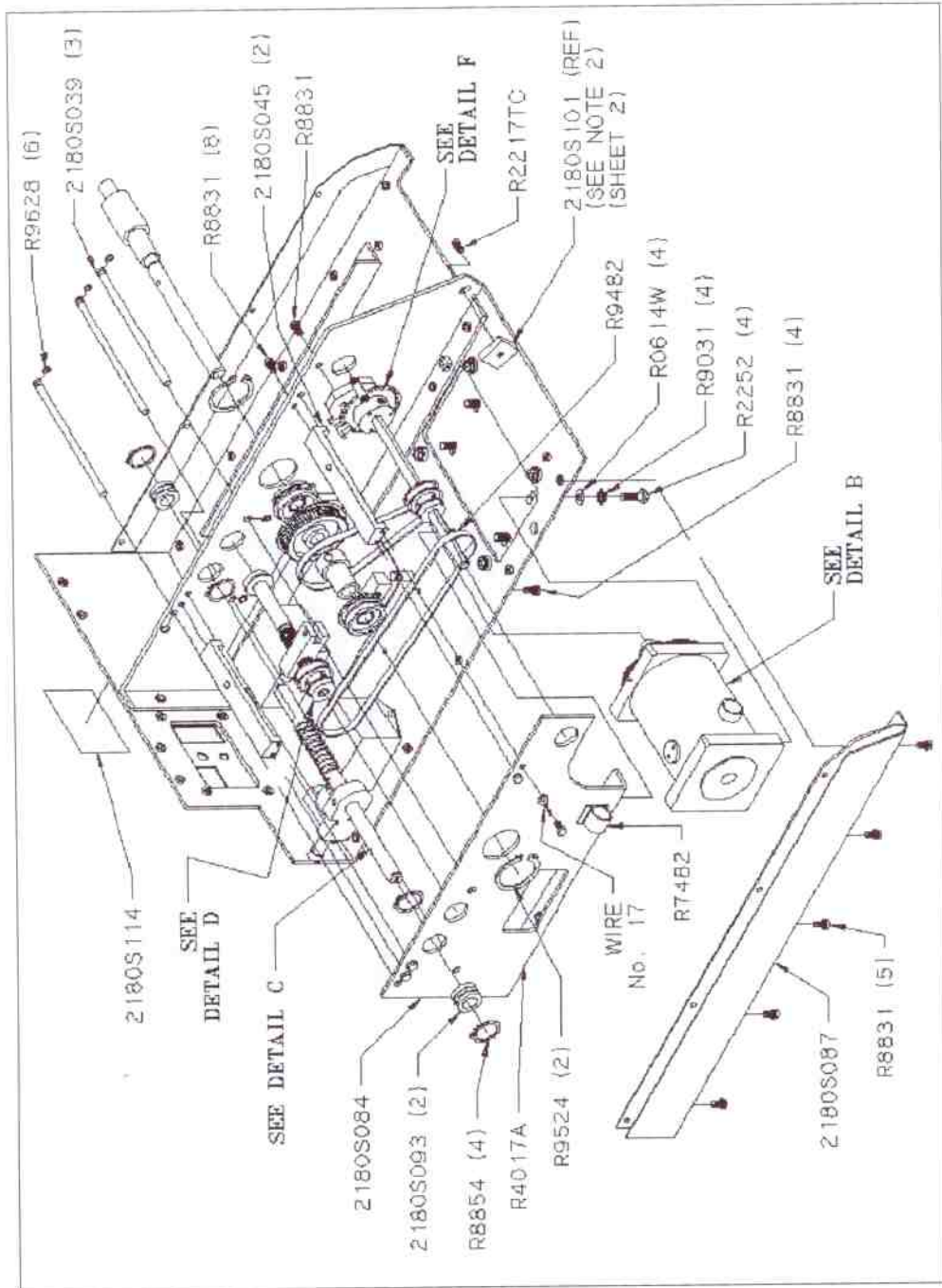

Figure 11 IsoMet® 1000 Assembly Diagram

IsoMet® 1000 Precision Saw Drawings

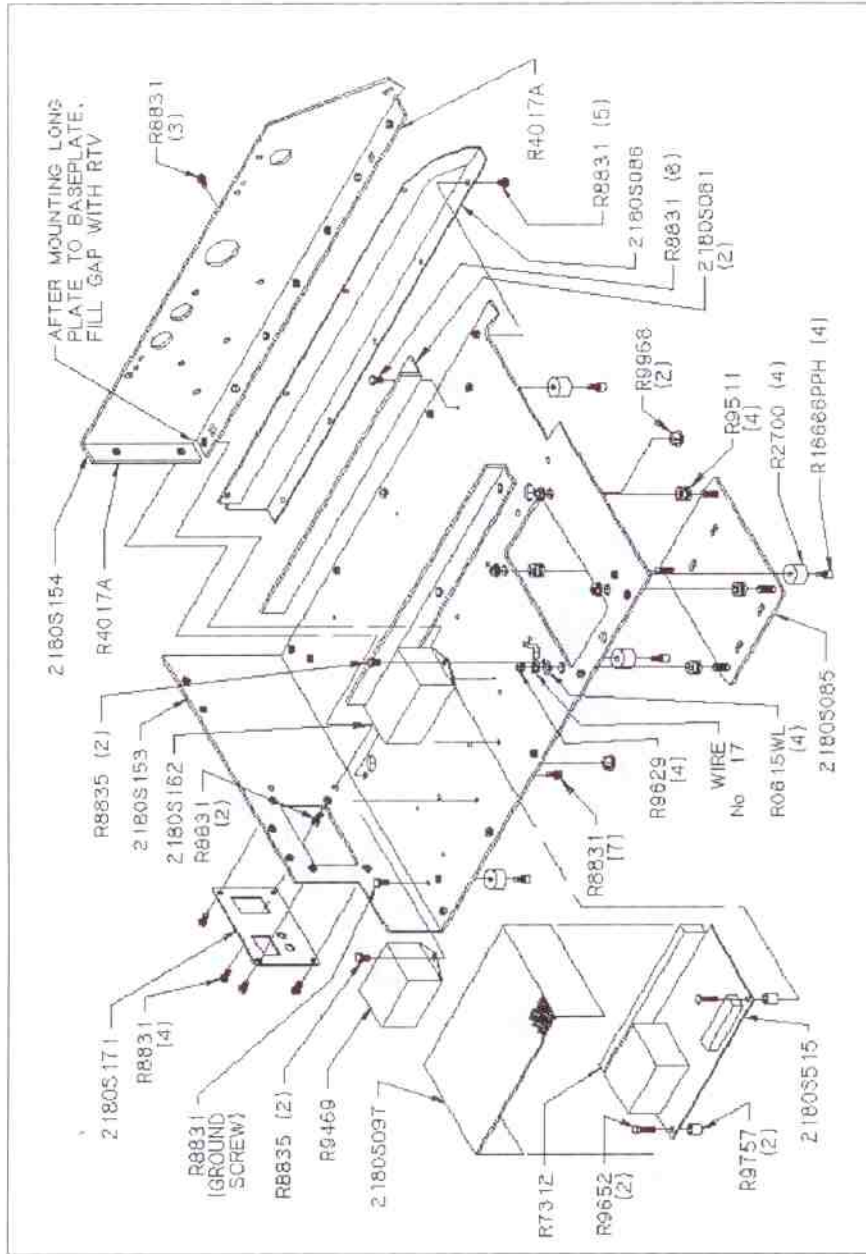

Figure 12 IsoMet® 1000 Assembly Diagram

IsoMet[®] 1000 Precision Saw Drawings

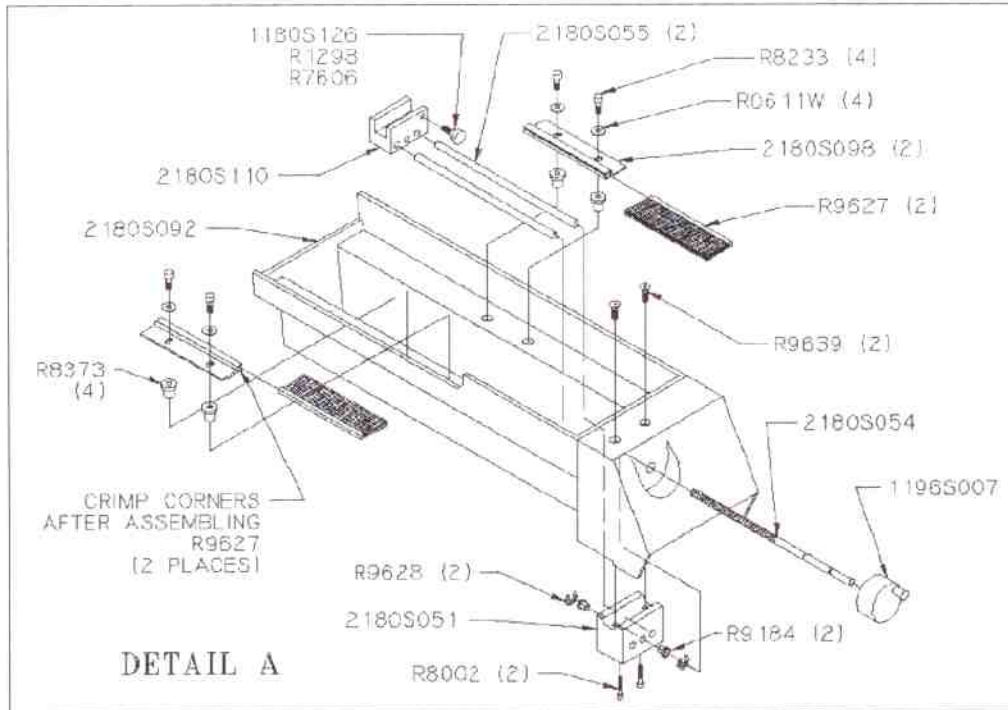

Figure 13 IsoMet[®] 1000 Lubricant Tray Assembly Diagram

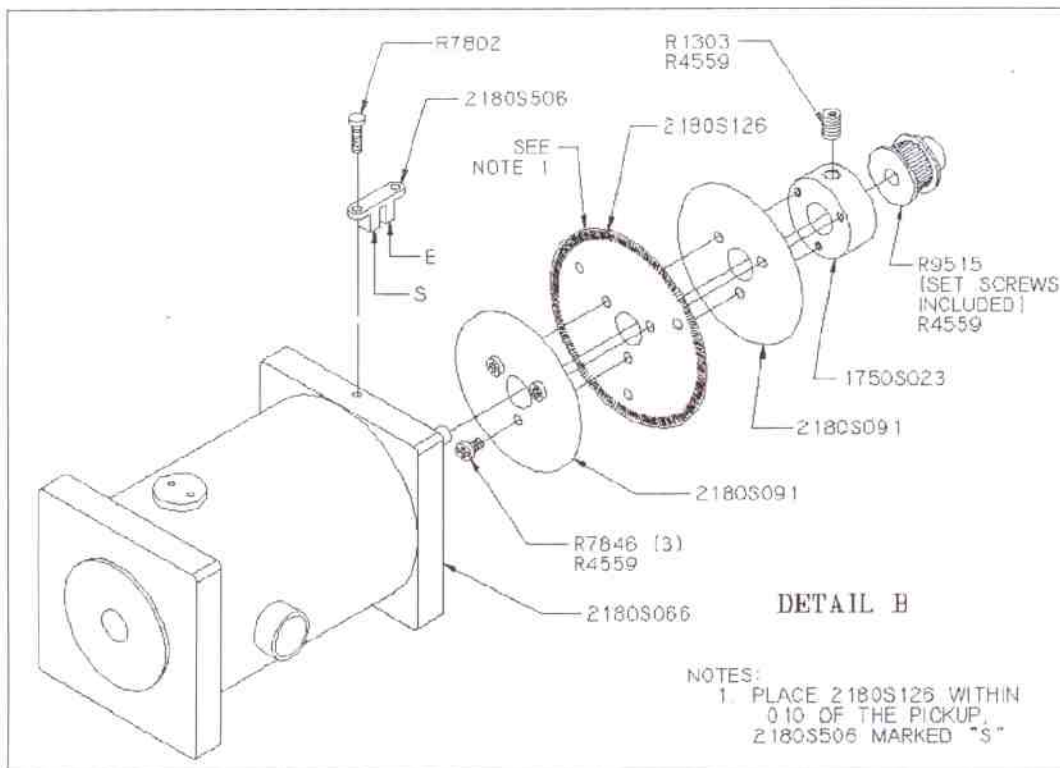

Figure 14 IsoMet[®] 1000 Motor Assembly Diagram

IsoMet[®] 1000 Precision Saw Drawings

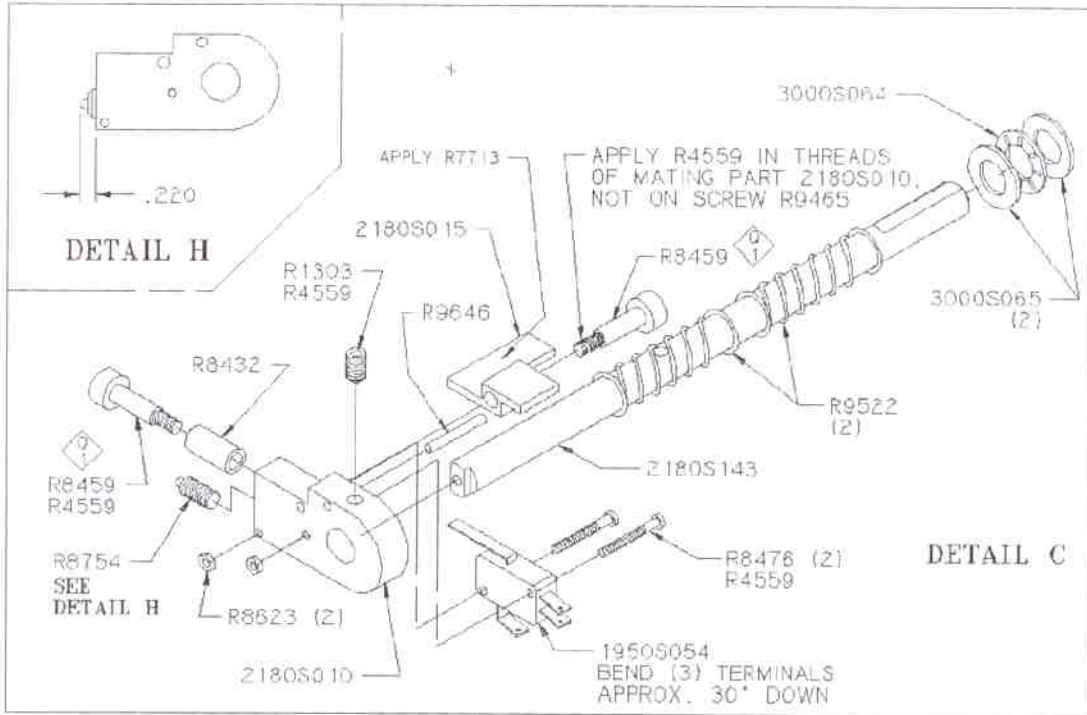

Figure 15 IsoMet[®] 1000 Weight Arm Support Shaft Assembly Diagram

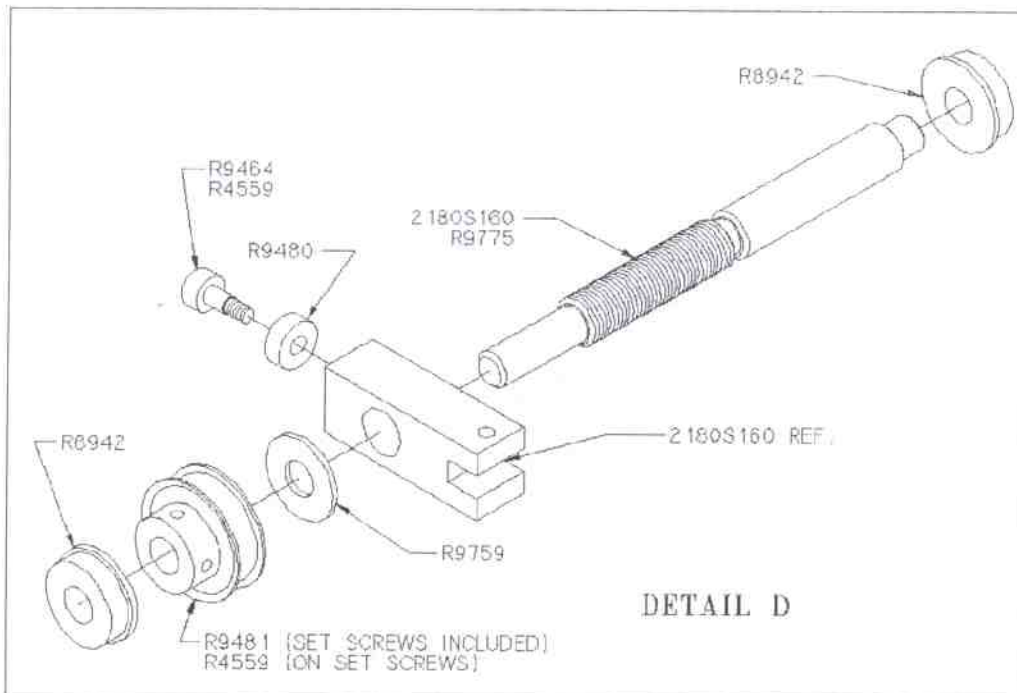

Figure 16 IsoMet[®] 1000 Sample Arm Support Shaft Assembly Diagram

IsoMet® 1000 Precision Saw Drawings

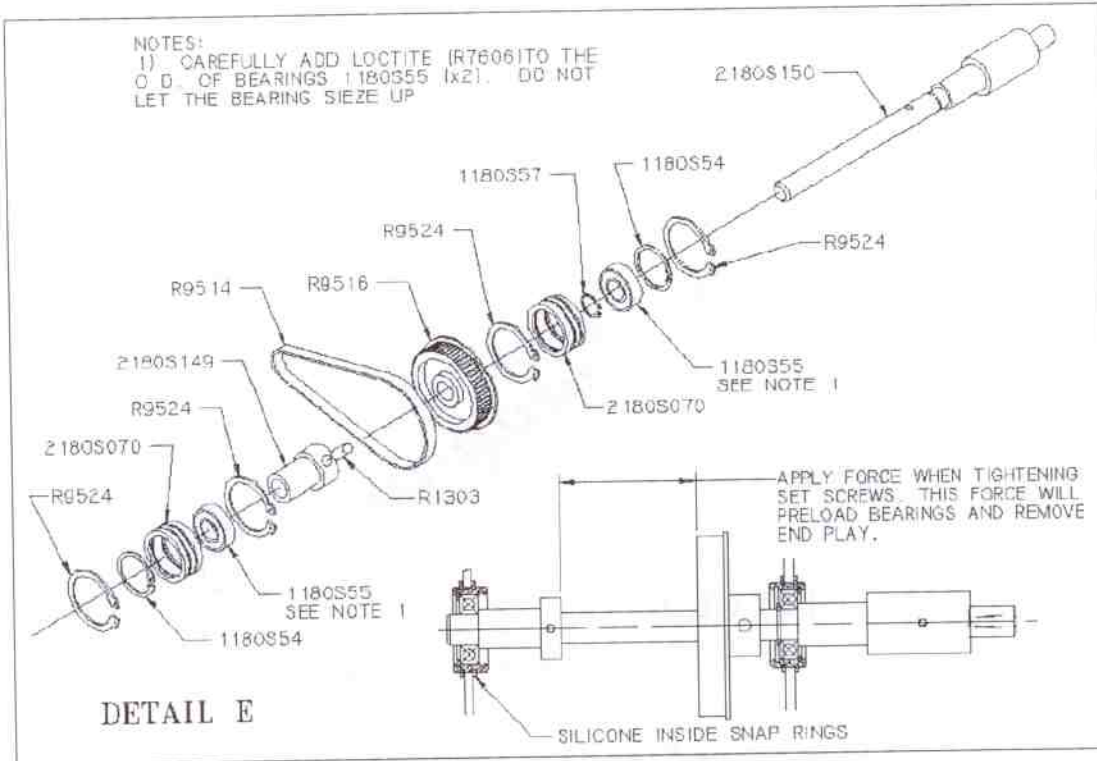

Figure 17 IsoMet® 1000 Motor Shaft Assembly Diagram

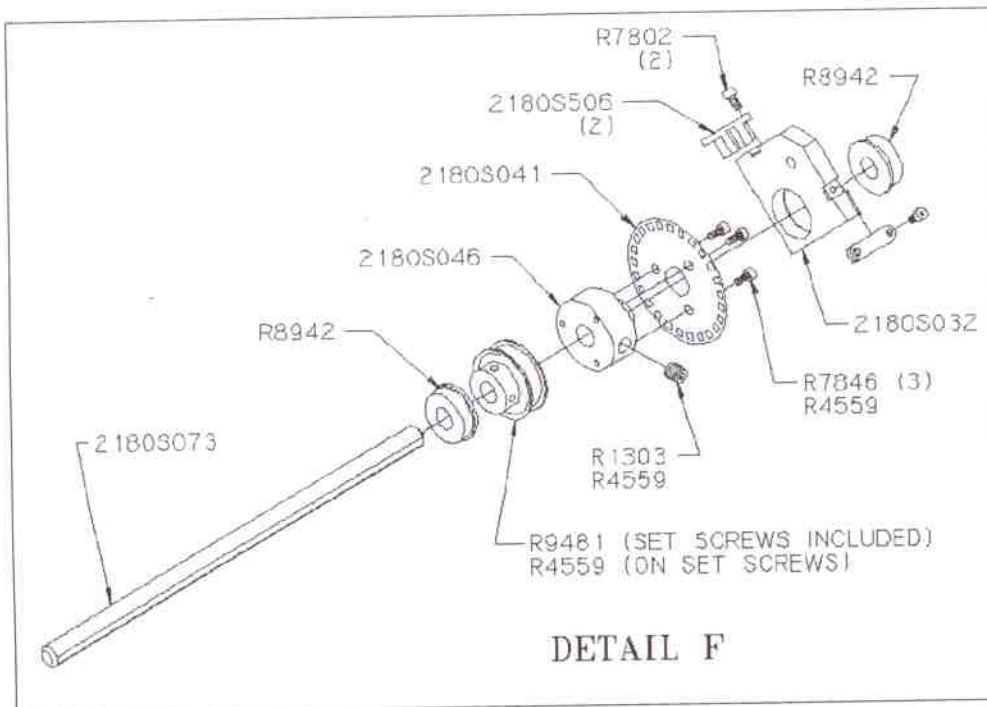

Figure 18 IsoMet® 1000 Sample Positioning Knob Shaft Assembly Diagram

IsoMet® 1000 Precision Saw Drawings

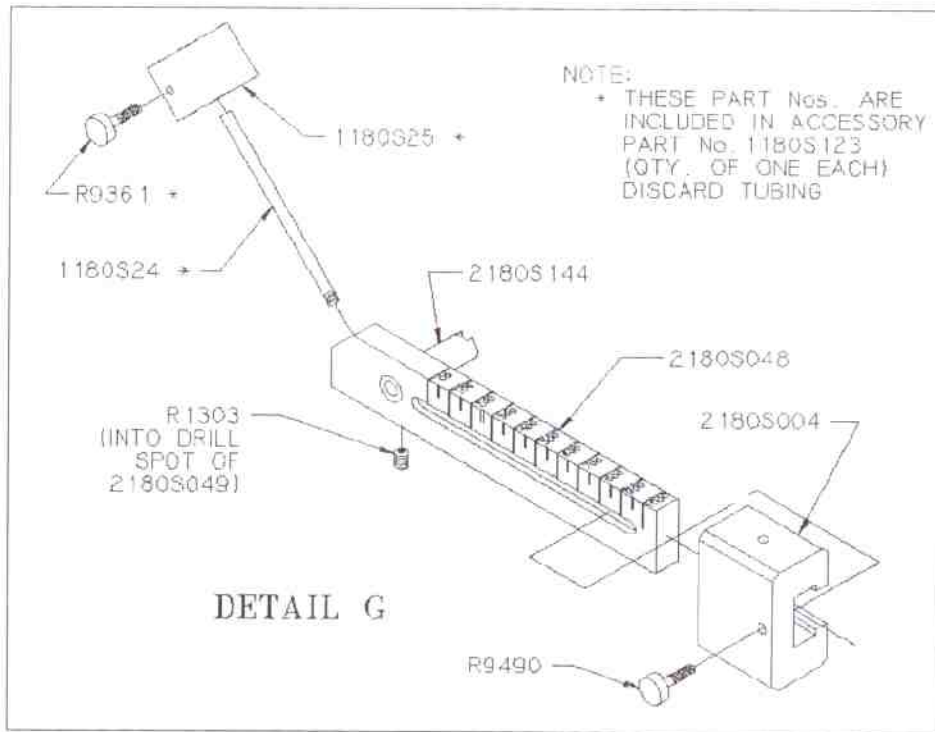

Figure 19 IsoMet® 1000 Weight Arm Assembly Diagram

IsoMet® 1000 Precision Saw Drawings

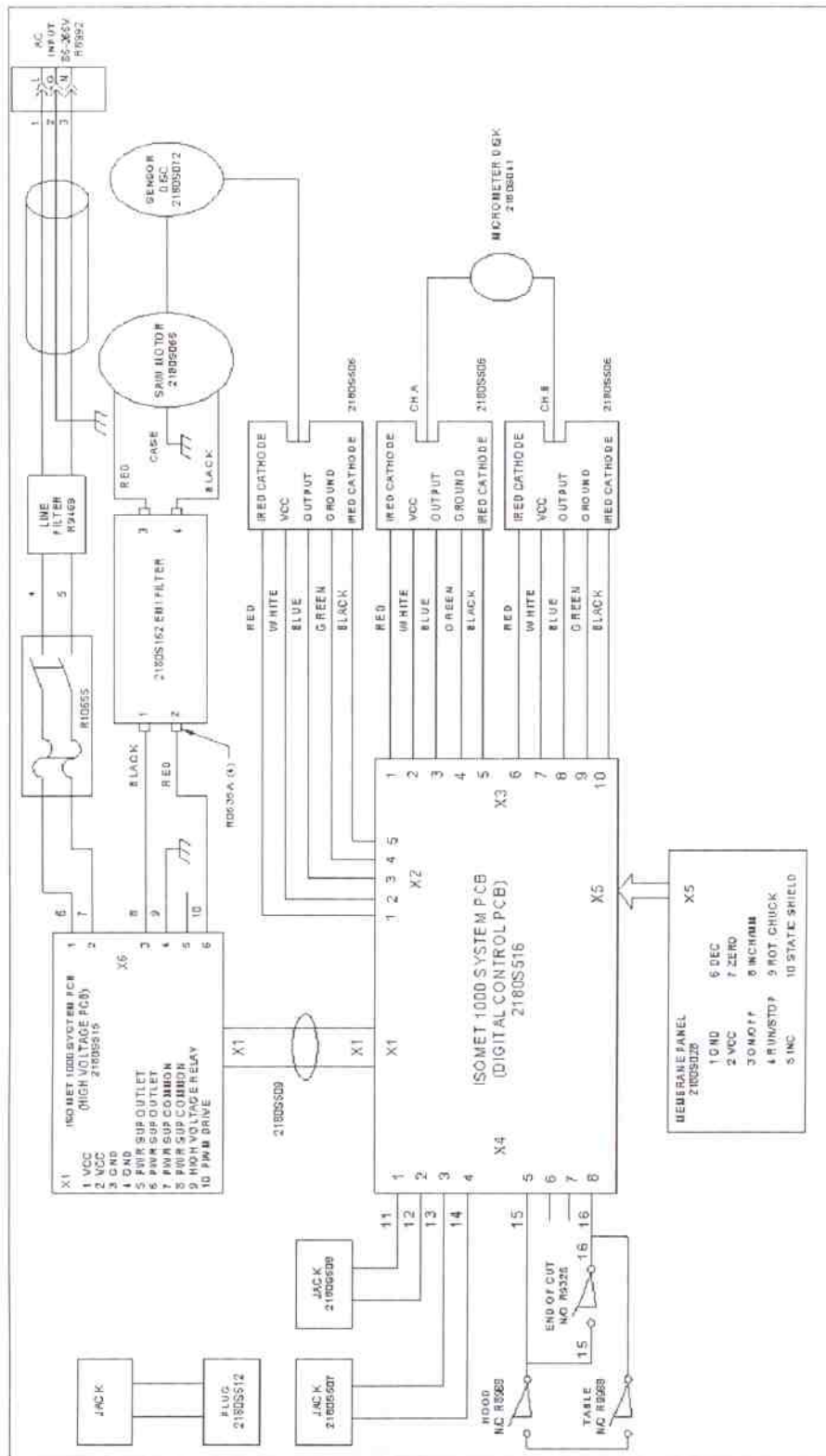

Figure 20 IsoMet® 1000 Electrical Diagram

IsoMet® 1000 Precision Saw Parts List

| Part Number | Description | Qty | U/M |
|-------------|--|-------|-----|
| MA112180 | IsoMet 1000 INSTRUCTION MANUAL | 1.00 | EA |
| R0545 | TERMINAL #8 BLACK SPADE 16-14 FI | 4.00 | EA |
| R0535A | TERMINAL #6 BLACK SPADE 22-16 FI | 4.00 | EA |
| R0603 | HEX NUT 4-40 STAINLESS STEEL | 2.00 | EA |
| R0605 | HEX NUT 6-32 STEEL CAD | 4.00 | EA |
| R0609LW | WASHER SPLK #8 | .00 | EA |
| R0611W | WASHER #10 FLAT | 4.00 | EA |
| R0612LWE | LOCK WASHER EXTERNAL #10 STAINLESS STEEL | 4.00 | EA |
| R0612W | WASHER #10 FLAT STAINLESS STEEL | 1.00 | EA |
| R0614W | WASHER 1/4 INCH | 4.00 | EA |
| R10031 | EPOXY 5 MIN. | 1.00 | EA |
| R10655 | CIRCUIT BREAKER 5 AMP | 1.00 | EA |
| R1298 | SET SCREW 10-32 X 3/4 STAINLESS STEEL | 1.00 | EA |
| R1303 | SET SCREW 1/4-20 X 1/4 STAINLESS STEEL | 7.00 | EA |
| R16666PPH | SCREW 10-32 X 1/2 PHILLIPS PAN STAINLESS STEEL | 4.00 | EA |
| R2217TC | SCREW 10-16 X 3/8 PHILLIPS PAN STAINLESS STEEL | 1.00 | EA |
| R2252 | HEX SCREW 1/4-20 X 1/2 STEEL ZINC | 4.00 | EA |
| R2700 | RUBBER BUMPER 3/4 DIAMETER X 9/16 BLACK | 4.00 | EA |
| R4017A | CLEAR ADHESIVE SEAL RTV 11 OZ. | 0.00 | TB |
| R4537 | HOLE PLUG .625 DIAMETER BLACK | 1.00 | EA |
| R4559 | ANAEROBIC ADHESIVE-THREAD GR. | 0.00 | EA |
| R7075 | STAKON WIRE JOINTS | 3.00 | EA |
| R7312 | THERMAL COMPOUND | 0.00 | LB |
| R7482 | COMPONENT CLIP 1/2 DIAMETER | 1.00 | EA |
| R7532 | CYANO ACRYLATE ADHESIVE | .01 | BT |
| R7606 | HIGH TEMP ADHESIVE | 1.00 | ML |
| R7713 | VACUUM GREASE | .01 | EA |
| R7758 | SCREW 1/4-20 X 3/8 PAN PH STAINLESS STEEL | 3.00 | EA |
| R7802 | SCREW 4-40 X 5/16 PAN PHIL STAINLESS STEEL | 3.00 | EA |
| R7821 | REEDS WITCH MAGNET | 1.00 | EA |
| R7846 | SCREW 6-32 X 1/4 PAN PHIL HD STAINLESS STEEL | 6.00 | EA |
| R8002 | SCREW 6-32 X 1/2 SOCKET HEAD | 2.00 | EA |
| R8067 | SCREW 4-40 X 3/8 FLAT PHIL STAINLESS STEEL | 2.00 | EA |
| R8233 | SCREW 10-24 X 7/8 SOCKET STAINLESS STEEL | 4.00 | EA |
| R8373 | NUT WELL 10-24 | 4.00 | EA |
| R8432 | POLYURETHANE TUBING 1/4 INCH ID | 0.083 | FT |
| R8459 | SCREW SHOULDER 10-24 SOCKET HEAD | 2.00 | EA |
| R8476 | SCREW 4-40 X 1-1/8 ROUND PHILLIPS | 2.00 | EA |
| R8623 | KEPS NUT 4-40 ZINC PLATE STEEL | 2.00 | EA |
| R8678 | SCREW 10-32 X 1 LARGE PAN HEAD | 4.00 | EA |
| R8744 | HEX NUT 1/4-20 HEAVY NYLON BLACK | 4.00 | EA |
| R8754 | SPRING PLUNGER 3/8-16 X .625 ST | 1.00 | EA |
| R8831 | SCREW 10-32 X 3/8 PHILLIPS W/W ST CD | 45.00 | EA |
| R8835 | SCREW 8-32 X 3/8 PHILLIPS W/W STEEL CD | 2.00 | EA |

IsoMet® 1000 Precision Saw Parts List

| Part Number | Description | Qty | U/M |
|-------------|---|------|-----|
| R8854 | RETAINING RING C CLIP .875 DIAMETER | 4.00 | EA |
| R8942 | BALL BEARING 3/8 ID FLANGED | 4.00 | EA |
| R8988 | MAGNETIC REED SWITCH | 2.00 | EA |
| R8992 | SNAP-IN IEC POWER INLET | 1.00 | EA |
| R9008A-D | IEC POWER CORD – COUNTRY OF USE | 0.00 | EA |
| R9031 | WASHER EXT 1/4 X .50 X .03 STAINLESS STEEL | 4.00 | EA |
| R9032 | NYLON SCREW 1/4-20 X 1 ROUND HEAD BLACK | 4.00 | EA |
| R9184 | NYLON BEARING, .25 ID X .25 | 2.00 | EA |
| R9408 | SPEED SENSOR | 2.00 | EA |
| R9464 | SCREW SHOULDER 8-32 X 3/8 STNL STEEL | 1.00 | EA |
| R9469 | INPUT LINE FILTER | 1.00 | EA |
| R9480 | BALL BEARING.187 X .50 X .156 | 1.00 | EA |
| R9481 | TIMING PULLEY 3 MM HTD X 3/8 BORE | 2.00 | EA |
| R9482 | TIMING BELT 3 MM P HTD X 171 T | 1.00 | EA |
| R9490 | THUMB SCREW 10-32 X 1.00 STAINLESS STEEL | 1.00 | EA |
| R9511 | HOLE GROMMET .26 ID X .62 OD | 4.00 | EA |
| R9514 | HTD TIMING BELT 3 MM P X 128 T | 1.00 | EA |
| R9515 | HTD PULLEY 3 MM P X 20 T-.25 BORE | 1.00 | EA |
| R9516 | HTD PULLEY 3 MM P X 60 T-.50 BORE | 1.00 | EA |
| R9522 | COMPRESSION SPRING .594 OD X .040 | 2.00 | EA |
| R9524 | RETAINING RING EXT. 1-3/8 X .056 | 4.00 | EA |
| R9584 | SYNTHETIC RUBBER BELLOW 1.26 OD | 1.00 | EA |
| R9623 | SCREW 6-32 X 3/8 SOCKET FLAT STNL STEEL PLATE | 8.00 | EA |
| R9627 | LARGE BRUSH 1.60 X 4 IN ISO 1000 | 2.00 | EA |
| R9628 | RETAINING RING E-STYLE .210 GR | 8.00 | EA |
| R9629 | HEX NUT 1/4-20 NYLOK STEEL ZINC | 4.00 | EA |
| R9639 | SCREW 10-32 X 1/2 SOCKET FLAT HEAD STNL STEEL | 2.00 | EA |
| R9646 | ROLL PIN 1/8 DIAMETER X 1.00 STNL STEEL | 1.00 | EA |
| R9652 | SCREW 8-32 X 3/4 SLOT BIND NY | 2.00 | EA |
| R9656 | THREAD ROD 1/4-20 X 2.75 STNL STEEL | 1.00 | EA |
| R9700 | SPEC CE APPROVED PLATE | 1.00 | EA |
| R9754 | SCREW 8-32 X 1-1/4 SOCKET STNL STEEL SPEC | 1.00 | EA |
| R9757 | SPACER .17 ID X .38 OD X .50 NY | 2.00 | EA |
| R9775 | ANTI-SEIZE COPPER LUBRICANT | .01 | CN |
| R9759 | WASHER .37 X .87 X .06 TEFLON | 1.00 | EA |
| R9849 | KNOB, 3/4D X 3/4L 1/4-20 UNC-2B | 1.00 | EA |
| R9968 | SCREW INSERT | 2.00 | EA |
| 1180S123 | COUNTER-BALANCE WEIGHT ASSEMBLY | 1.00 | EA |
| 1180S54 | RETAINING RING INT 1.125 ID | 2.00 | EA |
| 1180S55 | BALL BEARING .5000 ID 1.1250 OD | 2.00 | EA |
| 1180S57 | RETAINING RING EXT .500 | 1.00 | EA |
| 1180S72 | KEPS NUT 6-32 | 4.00 | EA |
| 1196S007 | SPINNER TYPE KNOB | 1.00 | EA |
| 1280S187 | THUMB SCREW 10-32 X .6 | 1.00 | EA |

IsoMet® 1000 Precision Saw Parts List

| Part Number | Description | Qty | U/M |
|-------------|----------------------------------|------|-----|
| 1750S023 | HUB SHAFT 1/2-INCH | 1.00 | EA |
| 1950S054 | TOP LIMIT SWITCH | 1.00 | EA |
| 2180S002 | IsoMet 1000 ARM | 1.00 | EA |
| 2180S004 | IsoMet 1000 WEIGHT | 1.00 | EA |
| 2180S010 | RIDER BLOCK | 1.00 | EA |
| 2180S015 | SWITCH ACTIVATOR | 1.00 | EA |
| 2180S027 | IsoMet 1000 HOOD | 1.00 | EA |
| 2180S032 | HANDLE MOUNT SHAFT | 1.00 | EA |
| 2180S033 | IsoMet 1000 HAND WHEEL | 1.00 | EA |
| 2180S039 | SHORT SHAFT | 3.00 | EA |
| 2180S041 | SENSOR DISK, 25 HOLE | 1.00 | EA |
| 2180S045 | IsoMet 1000 BAR | 1.00 | EA |
| 2180S046 | SENSOR HUB | 1.00 | EA |
| 2180S048 | WEIGHT ARM | 1.00 | EA |
| 2180S051 | DRESSING CHUCK MOUNT BLOCK | 1.00 | EA |
| 2180S054 | DRESSING CHUCK SCREW | 1.00 | EA |
| 2180S055 | DRESSING CHUCK SHAFT | 2.00 | EA |
| 2180S066 | MOTOR, 48 VOLT DC 3000 RPM | 1.00 | EA |
| 2180S070 | BEARING MOUNT | 2.00 | EA |
| 2180S086 | LOWER RIGHT SIDE | 1.00 | EA |
| 2180S087 | LOWER LEFT SIDE | 1.00 | EA |
| 2180S090 | IsoMet 1000 CABINET | 1.00 | EA |
| 2180S091 | SENSOR DISC FLANGE | 2.00 | EA |
| 2180S092 | COOLANT TANK | 1.00 | EA |
| 2180S093 | BEARING .500 ID X .875 OD TEFLON | 2.00 | EA |
| 2180S098 | IsoMet 1000 BRUSH MOUNT | 2.00 | EA |
| 2180S101 | CABINET BRACKET | 1.00 | EA |
| 2180S110 | IsoMet 1000 DRESSING CHUCK | 1.00 | EA |
| 2180S126 | SENSOR DISK .200 DIAMETER HOLES | 1.00 | EA |
| 2180S143 | PIVOT SHAFT | 1.00 | EA |
| 2180S144 | PIVOT EXTENDER SHAFT | 1.00 | EA |
| 2180S150 | SHAFT ARBOR | 1.00 | EA |
| 2180S153 | IsoMet 1000 ALUMINUM BASE | 1.00 | EA |
| 2180S159 | IsoMet 1000 PARTS KIT | 1.00 | EA |
| 2180S160 | MICROMETER SCREW / NUT SET | 1.00 | EA |
| 2180S162 | IsoMet 1000 EMI FILTER | 1.00 | EA |
| 2180S506 | SPEED SENSOR ASSEMBLY | 1.00 | EA |
| 2180S507 | MOTOR JACK ASSEMBLY | 1.00 | EA |
| 2180S508 | POWER JACK ASSEMBLY | 1.00 | EA |
| 2180S509 | RIBBON CABLE, 10-PIN X 24-INCH | 1.00 | EA |
| 2180S510 | IsoMet 1000 NAME PLATE | 1.00 | EA |
| 2180S513 | IsoMet 1000 HARNESS | 1.00 | EA |
| 2180S515 | IsoMet 1000 PCB POWER | 1.00 | EA |
| 2180S516 | IsoMet 1000 LOGIC PCB | 1.00 | EA |

IsoMet® 1000 Precision Saw Parts List

| Part Number | Description | Qty | U/M |
|-------------|-------------------------------|------|-----|
| 2180S999 | IsoMet 1000 COMMON COMPONENTS | 1.00 | EA |
| 2280S110 | SHAFT BUSHING END ANODIZED | 1.00 | EA |
| 2480S158 | HINGE SPACER | 4.00 | EA |
| 2480S219 | THUMB SCREW 10-32 X .63 | 2.00 | EA |
| 3000S064 | THRUST BEARING 1/2 INCH | 1.00 | EA |
| 3000S065 | THRUST WASHER 1/2 INCH | 2.00 | EA |

IsoMet® 1000 Precision Saw Packaging

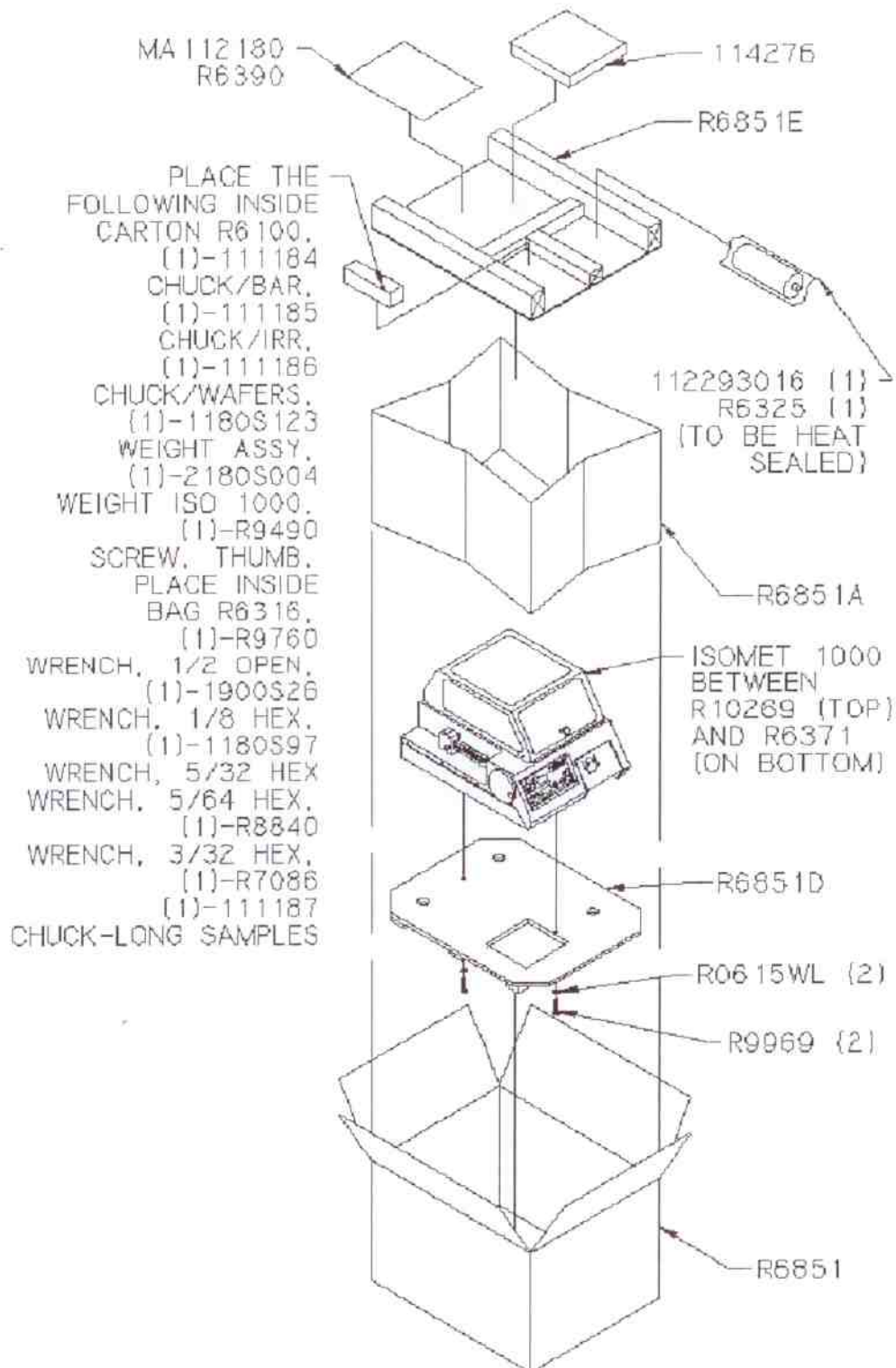

Figure 21 IsoMet® 1000 Packaging Diagram

IsoMet® 1000 Precision Saw Packaging Parts List

| Part Number | Description | Qty | U/M |
|-------------|--|------|-----|
| R0615WL | WASHER LARGE STAINLESS STEEL 1/4 INCH | 200 | EA |
| R10269 | POLY SHEET 48 X 72 - 2 MIL | 1.00 | EA |
| R6100 | CARTON 7X2X2 | 1.00 | EA |
| R6371 | POLY SHEET 36 X 48-2 MIL | 1.00 | EA |
| R6851 | CARTON, 25 1/8 X 20 1/8 X 17 3/4 | 1.00 | EA |
| R6851A | TAPED TUBE | 1.00 | EA |
| R6851D | PLYWOOD BASE | 1.00 | EA |
| R6851E | HOLD DOWN TOP | 1.00 | EA |
| R6316 | POLY BAG 4 X 6-4 MIL | 1.00 | EA |
| R6325 | POLY BAG 8 X 10-4 MIL | 1.00 | EA |
| R6390 | ENVELOPE, WARRANTY-9 X 14 X 4 MIL | 1.00 | EA |
| R7086 | HEX WRENCH SHORT ARM 1/32 | 1.00 | EA |
| R8840 | HEX WRENCH SHORT ARM 5/64 | 1.00 | EA |
| R9760 | OPEN END WRENCH 1/2 - 5/8 INCH | 1.00 | EA |
| R9969 | LAG SCREW 1/4 X 1-1/2 ST ZINC | 2.00 | EA |
| 111184 | BAR & TUBE STOCK CHUCK | 1.00 | EA |
| 111185 | IRREGULAR SAMPLES CHUCK | 1.00 | EA |
| 111186 | WAFERS CHUCK | 1.00 | EA |
| 111187 | LONG SAMPLES CHUCK | 1.00 | EA |
| 112282 | FLANGE SET 3-INCH OF 2 | 1.00 | EA |
| 112293-016 | ISOCUT PLUS FLUID - PINT | 1.00 | EA |
| 114276 | WAFERING BLADE 6 X .020 X 1/2 15 LC SERIES | 1.00 | EA |
| 1180S97 | HEX WRENCH 5/32 STEEL CD PL | 1.00 | EA |
| 1900S26 | HEX WRENCH 1/8 | 1.00 | EA |
| 2180S911 | IsoMet 1000 SAW BASE UNIT ASSEMBLY | 1.00 | EA |

Buehler Office Addresses World Wide

Buehler Ltd.

41 Waukegan Road
Lake Bluff, IL 60044
USA
Tel: (847) 295 6500
Fax: (847) 295 7979
Service Fax: (847) 295 7954
E-mail: service@buehler.com

Buehler UK

Saturn Building
101, Lockhurst Lane
Coventry, CV6 5SF
England
Tel: (+44) (0) 24 7658 2158
Fax: (+44) (0) 24 7658 2159
E-mail: service@buehler.co.uk

Buehler GmbH

In der Steele 2
40599 Düsseldorf
Postfach 16 03 55
40566 Düsseldorf
Germany
Tel: (+49) (0211) 974 1000
Fax: (+49) (0211) 974 1079
E-mail: service@buehler-met.de

Buehler S.A.R.L.

Miniparc de Dardilly, Batiment 0
3, Chemin du Jubin
69570 Dardilly - France
Tel: (+33) (04) 37 59 81 20
Fax: (+33) (04) 37 59 81 29
Service Fax: (+33) (04) 37 59 81 25
E-mail: sar@buehler.fr

Buehler Canada

9999 Highway 48
Markham, Ontario L3P 3J3
Canada
Tel: (905) 201 4686
Fax: (905) 201 4683
Buehler Canada Website: www.buehler.ca
Email: info@buehler.ca

Buehler South Asia / Pacific

5/R Vogue Centre
696 Castle Peak Road
Lai Chi Kok, Kowloon
Hong Kong, SAR, China
Tel: (852) 2307 0909
Fax: (852) 2307 0223
E-mail: info@buehler.com.hk